



OWNER'S MANUAL AND OPERATING INSTRUCTIONS

Air Compressor

24L 2.0HP DIRECT DRIVE



WARNING: SAVE THIS MANUAL FOR FUTURE



This manual contains important information regarding safety. Operation, maintenance, and storage of this product. Before use, read carefully and understand all cautions, warnings, instructions and product labels. Failure to do so could result in serious personal injury and/or property damage.

TABLE OF CONTENTS

Thank You For your Purchase	3
Unpacking Your New Compressor	3
Hazards and Safety	4
Work Area Safety	4
Personal Safety.....	4
Electrical Safety	5
Air compressor Safety.....	5
Technical Description	6
Compliance Plate	6
Performance and Duty Cycle	6
Input Plug	7
Operating Environment.....	7
Machine Layout	8
Assembly	9
Filling Compressor with Oil	10
Starting and Stopping	11
Checking the Safety Relief Valve	11
Air Pressure Regulation and Hose Connection	12
Maintenance	13
Replacing Pump Oil	13
Cleaning / Replacing Air Filter	13
Draining the Tank.....	14
Non-return Valve	14
Trouble shooting	15
Warranty Statement	16
Exploded Diagram	17
Parts List	18
Notes	19

Thank you for your Purchase.

Powerbuilt would like to thank you for purchasing the AC2420 air compressor.

This manual is designed to guide you through using your new machine.

UNPACKING YOUR COMPRESSOR



Contents:

- Air Compressor
- Air Cleaner
- Wheels x 2
- Rubber front foot x 2
- Wheel axle, nut and washer x 2
- M8 Bolt, nut and washer x 2
- Bottle of oil (not shown)
- Owners manual (not shown)



Please check all contents are correct and damage free before first use, if any issues please contact your local dealer.



WARNING HAZARDS AND SAFETY

Read all safety warning and all instructions.

This Operating Manual has been designed to instruct you on the correct operation of your Powerbuilt product. Your satisfaction with this product and its safe operation is our ultimate concern. Therefore, please take the time to read the entire manual, especially the safety symbols and instructions. They will help you to avoid potential hazards that may exist when working with this product. Every effort has been made to ensure that information in this manual is accurate and current. However, we reserve the right to change, alter, or otherwise improve the product and this document at any time without prior notice. Failure to follow the warning and instructions may result in electric shock, fire and or serious injury to you or others.

Save this manual for future reference.

WORK AREA SAFETY

- Ensure your work area is clear, dry and free of trip hazards.
- Do not operate the compressor in dangerous environments.
- Ensure the area is well ventilated, and all flammable materials are removed to a safe distance, normal sparking of the electrical motor could ignite fumes.
- Keep children and other visitors away. Do not let children or others contact the compressor, electrical lead or air leads.
- Never leave your compressor running unattended.
- Keep guards in place and in working order. Never operate this product with any guard or cover removed. Make sure all guards are intact and operating properly before each use.
- Remove adjusting tools and wrenches. If any adjustments or maintenance has been performed, make sure that all tools and adjusting wrenches are removed from product before use.
- Keep the work area clear of all persons, particularly small children, and pets.
- Only use product for its intended use.
- Don't force product or attachment to do a job it was not designed for.

PERSONAL SAFETY

- Use proper clothing. Wear long pants and long sleeves. Do not wear loose clothing, neckties, or jewelry. They can get caught and draw you into moving parts. Rubber gloves and nonskid footwear are recommended when working outdoors. Do not operate the equipment while barefoot or when wearing sandals or similar lightweight footwear.
- Always wear proper eye protection with side shields marked to comply with the correct AS/NZS STANDARDS. Following this rule will re-duce the risk of serious personal injury.
- Also wear protective hair covering to contain long hair.
- Stay alert, watch what you are doing. Do not use this tool when you are tired.
- Protect your lungs, wear a dust mask when operating product in dusty environments.
- Protect your hearing, wear hearing protection during extended periods of operation.
- Do not overreach. Keep proper balance and footing at all times.
- Use only recommended accessories with this product. The use of improper and or modified accessories may cause risk of injury.

ELECTRICAL SAFETY



ELECTRICITY CAN KILL

- Guard against electrical shock by preventing body contact with grounded surfaces, e.g., pipes, radiators, ovens, refrigerator enclosures.
- Do not abuse cord. Never carry or drag the compressor by the cord or yank it to disconnect from wall socket. Keep cord away from heat, oil, and sharp edges. Do not drive over or place heavy objects on electrical cord.
- Should any electrical component of the compressor fail to perform properly, shut off the power switch, remove the plug from the power source and replace/repair before resuming operation.
- Do not expose compressor to rain or wet conditions. Water entering the electronics will increase the risk of electric shock and damage the compressor.
- it is recommended that the compressor be connected to an RCD.

AIR COMPRESSOR SAFETY



WARNING

- **This air compressor does not produce breathable air.** Breathing compressed air is dangerous and can cause harm.
- Hot surfaces are present. DO NOT touch the motor, cylinder, heads and tubes as harm may occur from burning.
- DO NOT use in potentially explosive atmospheres. Ensure that the atmosphere is free from combustible gases and high concentrations of fine dust.
- Never apply the outlet air of this compressor directly on to any part of a person's body. Do not attempt to block the air outlet with your finger or any part of your body.
- Do not attempt to adjust the pressure switch or the release valve located under the pressure switch cover.
- Drain the moisture from the tank after use. It will help prevent corrosion and increases tank capacity.
- Pull the ring on the safety valve daily to ensure that it is operating properly and to clear any possible debris from the outlet.
- Keep the compressor at least 300mm from the nearest wall to ensure adequate ventilation for cooling purposes.
- Before transporting the compressor make sure that the pressurized air is bled from the tank and that the compressor is firmly secured.
- Protect the air hose and electrical lead from damage. Inspect for weak or worn spots regularly and replace if necessary.
- Always plug the compressor directly into the electrical outlet.
- Avoid using an extension cord with this product. Use additional air hose instead of an extension cord to prevent power loss and possible damage to the motor.

TECHNICAL DESCRIPTION

SPECIFICATION	UNITS	AC2420
Drive		Direct Drive
Motor	Winding	Copper
Tank Size	L	24
HP	Hp	2
Motor RPM	RPM	2850
Pump RPM	RPM	2850
Air Pressure	psi	0-120
Displacement	CFM	200 L/min (7CFM)
Free air Delivery	@90PSI	120 L/min (4.24CFM)
Bar	bar	8
Wheel Size	mm	125
Voltage		230V/50HZ
PLUG	amps	10A
N.W	kg	24
G.W	kg	26
Size (L x W x H)	mm	600 x 255 x 600

PERFORMANCE AND DUTY CYCLE

This medium duty compressor is not designed for continuous use, spray equipment or heavy-duty air tools.

Attempting to use air tools with a requirement of over 120L/min Free air delivery will reduce the performance of the air tool.

Pressure Cycle

The compressor forces air into a storage tank, increasing the pressure until it reaches an upper pressure limit at which the compressor shuts off. When the compressed air is being used by a tool the pressure decreases until the tank reaches its lower pressure limit, at that point the compressor turns on (via the pressure switch) to re-pressurize the tank. This is the compressor pressure cycle.

Compressing air produces heat if the compressor is used outside its duty cycle and the heat is not managed the compressor will be damaged. When the compressor turns off (via the pressure switch, after reaching maximum tank pressure) it has time to cool down while the air in the tank is being consumed. When a tool consumes the stored air quickly the time for cool down is reduced because the unit needs to restart to repressurize. If too short a time is dedicated to the cool down phase the compressor can overheat and become damaged.

Duty Cycle

The ratio between the pressurization and cool down phases is called the Duty Cycle.

To determine whether we need a Trade or DIY compressor we must first understand duty cycles. The duty cycle is a 10 min test. How long over a 10min period is the pump/tool running for.

- 2 min on – 3 min rest – 2 min on – 3 min rest = 40% Duty Cycle.
- 5 mins on – 5 mins rest = 50% Duty Cycle.
- 1 min 30 sec on 8 mins 30 sec rest = 15% duty cycle.

Whilst running a vehicle in the red zone all the time is great to get you where you need fast!! It dramatically shortens the life of the vehicle's engine. The same is said with duty cycles – to obtain the best life and performance out of your tool or compressor purchase a compressor that suits your application. If you think you'll be using high air consumption tools in a continuous manner consider a compressor with a higher FAD rating and/or larger storage tank to reduce the risk of wearing out or overheating the unit.

Direct Drive compressors: have the pump joined directly to the motor. This means the pump runs at 2800 RPM with a short piston stroke. This style of compressor has a duty cycle of 30-40% or is designed to run for short periods of continuous use – no more than 10mins of continuous pumping.

Belt Drive compressors: have the pump and motor separated. This allows the pump speed to be reduced to 1030RPM and allows for increased piston stroke, resulting in larger air deliveries compared to the direct drive style. Due to the slower speeds of the pump the compressor will produce cooler air with less moisture. Belt drive compressors have increased duty cycles 50-60%.

INPUT PLUG

The compressor is fitted with a **10amp** plug. This machine is designed to work with **10amp** wall sockets. It is important that the machine is plugged directly into the mains plug.

Avoid using an extension cord with this product. Use additional air hose instead of an extension cord. Using extension cords will reduce the input voltage (known as voltage drop) and this will void the warranty of your machine.

Any modification to the 10amp plug on this compressor will void warranty.

OPERATING ENVIRONMENT

- Operating temperature: -10°C~40°C.
- Transportation and storage: -25°C~55°C.
- Relative air humidity: 40°C ≤ 50%; 20°C ≤ 90%.
- The dust, acids, corrosive gases and substance in the ambient air must be not higher than normal level.
- Altitude must be less than 1km.
- Good ventilation around the machine, at a distance of at least 300mm around.
- Compressor must be kept on a level surface to reduce the risk of the machine falling.

MACHINE LAYOUT

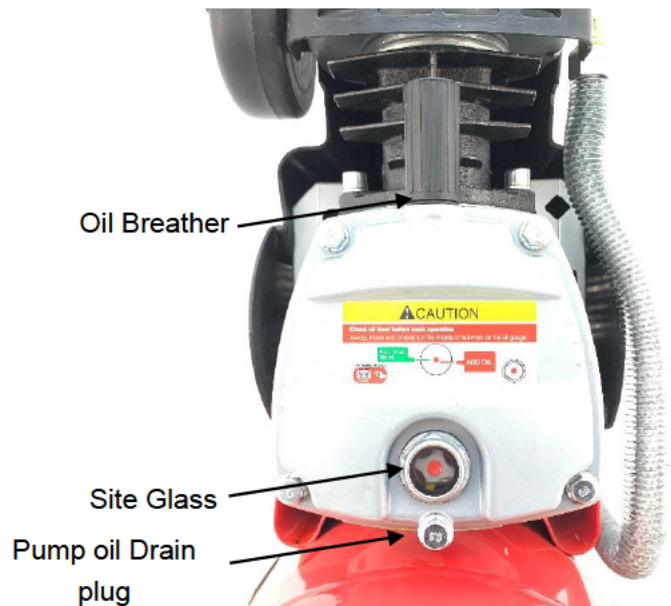
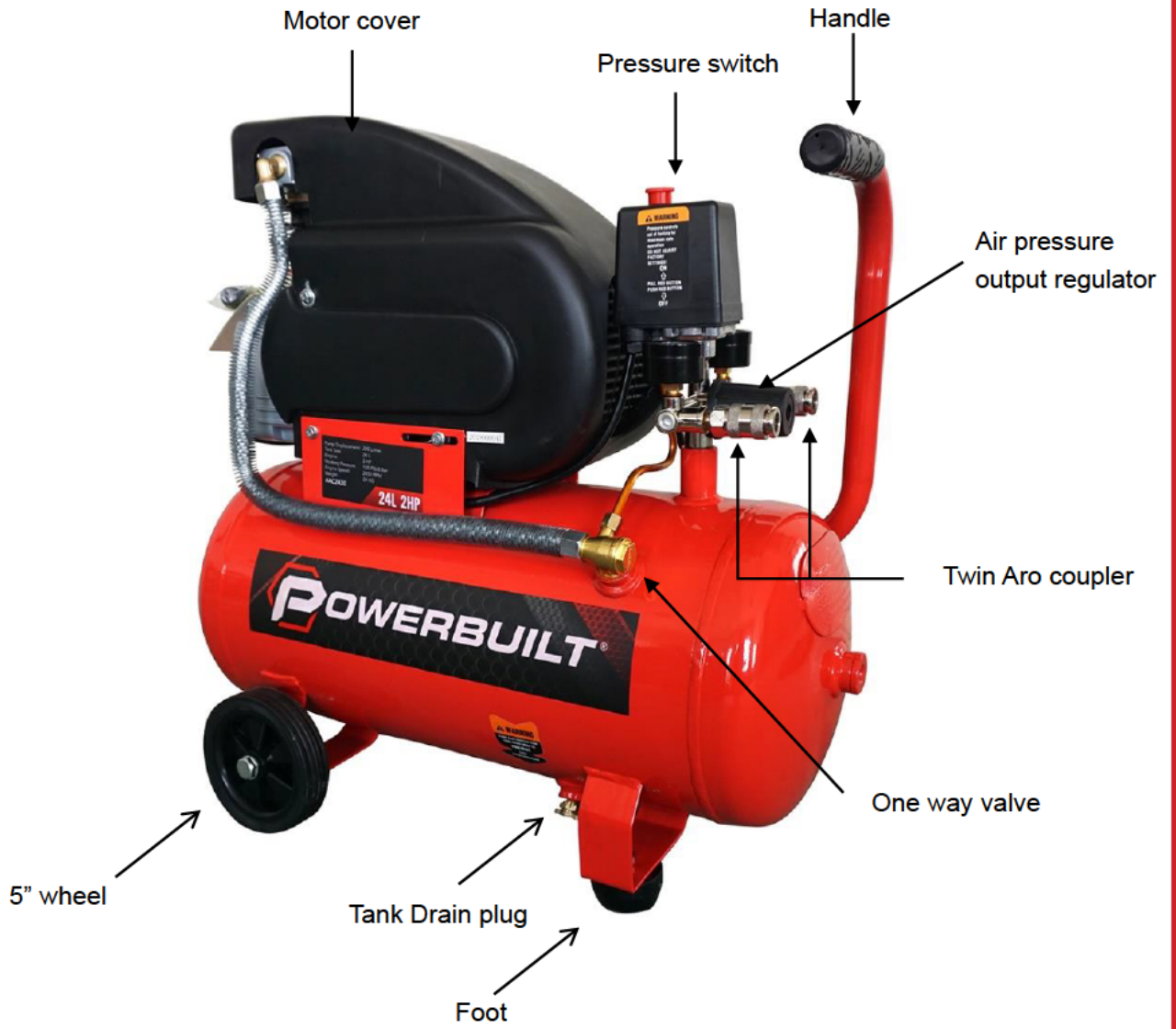

Important – your compressor is not filled with oil for shipping

ASSEMBLY



WARNING

Do not connect to the power supply unit the unit is completely assembled and all safety checks have been performed.

INSTALLING THE FEET

- Insert the M8 Bolt into the rubber foot with the thread exiting at the top.
- Insert the bolt from the foot into the supporting bracket located on the bottom of the compressor.
- Place the washer and nut onto the bolt and tighten
- Repeat for the other foot.



INSTALLING THE WHEELS

- Insert the Axle bolt into the wheel and locate onto the tank bracket.
- Place the washer and nut onto the bolt and tighten.
- Ensure the wheel spins freely.
- Repeat for the other wheel.



INSTALLING THE AIR FILTER

The supplied air filter must be fitted.

Failure to do so may result in irreparable damage and void warranty.

- Carefully screw in the supplied air filter into the threaded hole located on the pump head. It is important to use the supplied air filter as using the incorrect filter will reduce air flow to the pump.
- Do not over tighten.



FILLING COMPRESSOR WITH OIL



WARNING

There will be some residual oil from the pump manufacture, testing and lubrication. Do not operate until the oil is filled to the correct level.

Your compressor comes complete with a bottle of compressor oil.

- Remove and dispose of the travel bung.
- Using the supplied oil and a funnel (not supplied) fill the pump until the oil is at the middle of the red dot. The oil will take about a minute to drain down and setting, be careful not to over fill.
- Install the oil breather and screw hand tight – do not over tighten
- Recheck oil and top up if required, until the correct level is reached.



The middle of the red line is the maximum oil level. The bottom of the red dot and below indicates the oil is below the recommend level and oil should be added.



STARTING AND STOPPING COMPRESSOR



WARNING

Always plug your compressor directly into you the power socket. Never use an extension cord as this will lead to voltage drop, reducing the available power to your compressor. This may overheat or burn out your air compressor motor. Use additional air hoses to get to your work area.

Always start and stop your compressor by the pressure switch do not use the ON /OFF wall socket switch as the main control for the compressor. The pressure switch releases pressure between the one-way valve on the tank and the pump head. Starting your compressor motor with zero pressure, enhancing motor life. It is normal to hear a short hiss when the motor stops. The pressure switch starts the motor when the air tank (receiver) drops below the factory set cut-in pressure and stops the motor when the tank pressure reaches the factory set cut-out pressure.

Note: The pressure switch operation is related to motor horsepower, tank rating and safety valve setting. Do not attempt to adjust remove or by-pass the pressure switch, or change and modify any pressure control related device.

TO TURN ON

- Lift up the RED ON / OFF switch located on top of the pressure switch.

TO TURN OFF

- Push down the RED ON / OFF switch located on top of the pressure switch.

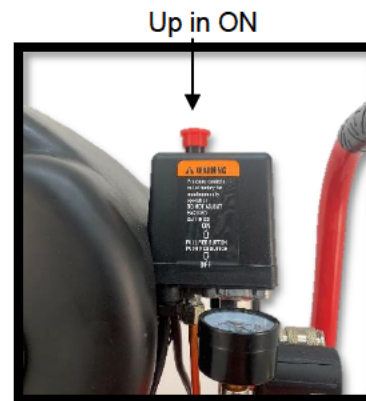

CHECKING THE SAFETY RELIEF VALVE (if fitted with ring)

The pressure relief valve will automatically release air if the tanks (reciever) exceeds the maximum preset by the factory. The valve should be checked daily before use by pulling the ring on the valve by hand. Wear safety glasses and hearing protection when testing.

- Start the comprsser and let the tank fill untill the pressure switch shuts off the compressor.
- Turn the compressor off.
- Pull the ring on the safety valve holding the value (pin) open for 5 seconds – air should escape rapidly. Release the ring and air should stop.
- If the pin remains open push the pin back in (this should only need to happen at high pressure).

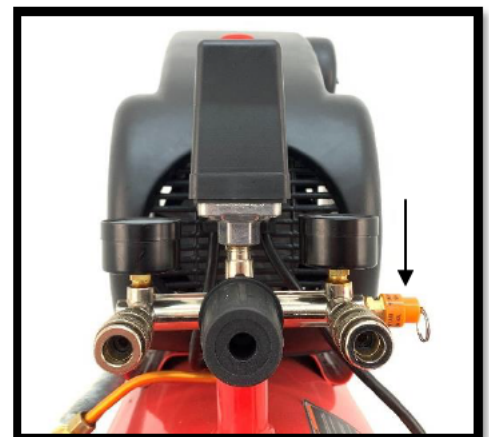

- If the valve continues to leak and the pin can not be acuated by the ring, do not use the compressor until the safety valuve is replaced. Using a compressor with a faulty valve can result in serious injury.

AIR PRESSURE REGULATION AND HOSE CONNECTION

Your Powerbuilt compressor is fitted with 2 Aro quick connect couplers and 1 air regulator.

TO ADJUST PRESSURE

- Rotate pressure regulator knob to the desired outlet pressure, this will adjust the pressure to both Aro quick connect couplers, ensuring you get the desired pressure.
- Turn the knob clockwise to increase the pressure and anti-clockwise to decrease the pressure.

It is always reccomended to use the minimum amout of pressure nessary for your intended application. Unsing higher pressure than required will only drain the tank faster and cause the compressor to cycle more frequently.



CONNECTING AIR HOSES

- Ensure the air hose has a male ARO Quick connect fitting connected to the air hose.
- Slide and hold the outer collar towards the compressor.
- Push in the male ARO fitting. Release the collar, continue to push the male fitting into the female fitting until you hear a click.

Even a small leak wastes a large amout of air, you will enhance the life of your compressor if you keep all outlets, hoses, couplings and air tools free from leaks. Even a small 1.5mm pin hole at 120PSI will waste nearly all of the out put from a 2hp compressor. If you notice a fall-off in the performance of your compressor, first check your system for leaks.

MAINTENANCE



WARNING

Always disconnect from power, release all pressure and allow unit to cool before carrying out any maintenance.

REPLACING PUMP OIL

Replace the oil after the first 10 hours of operation and every 120 hours following the first oil change.

If the oil colour changes (**whitening** – water present, **Black** – severe over heating) change the oil immediately.

The sight glass indicates the oil level and lets the operator check if oil should be added.

- Place a suitable container underneath the drain to collect used oil
- Remove the drain plug using a wrench.
- When the used oil has drained, reinstall the drain plug and tighten with the wrench.
- Unscrew the cap of oil fill hole.
- To refill, refer to page 10 FILLING WITH OIL

Refill only with SAE-30 oil.



Pump oil Drain
plug

CLEANING / REPLACING AIR FILTER

NEVER RUN YOUR COMPRESSOR WITHOUT AIR FILTERS

The air filter prevents dust, dirt and small items being drawn into the compressor – dirty air filters reduce the amount of air flowing into the compressor and will dramatically reduce your compressor's performance.

Normal environment.

Check and clean filter once a month, replace damaged or heavily clogged filters.

Dusty environment.

Check and clean filter weekly, replace damaged or heavily clogged filters.



Foam internal
filter.

DRAINING THE TANK

To prevent the tank from corrosion and reduce moisture in the air Delivery, the air tank should be drained daily or if working in high heat and humidity drain the tank more often.

- Turn the air compressor off and unplug.
- Drain most of the air from the compressor until about 1.5bar or 22 psi is left in the tank.
- Move the compressor to an area that wont be effected by the moisture and air flow.
- With safety glasses on turn the valve to the OPEN position (down).
- If your compressor is to be stored for long periods of time leave the safety valve open to allow moisture to drain. It might pay to leave a small container under the compressor if its to be stored with the valve open.



PRESSURE SWITCH – NON RETURN VALVE

Pressure switches are fitted with a soft start valve which will release air from the switch until approximatley 20PSI of pressure is reached, then they cut off.

If pressure switch continues to release air even when switched off it is possible the non return valve needs to be cleaned or replaced if damaged.

- Unplug the compressor from the mains switch.
- **Drain all air from the compressor – Failure to do this can result in serious injury or damage to you or those around you.**
- Open the tank drain valve to ensure the tank is completely drained of all air.
- Remove cap on the non return valve, remove spring and rubber stopper.
- Inspect brass valve for loose material stopping the boot from sealing against the valve. Check the boot for cuts or miss formation – replace if required.
- If the valve continues to leak once this procedure is followed take compressor to local serice agent for inspection and repair.



Pressure Switch

Non-return Valve

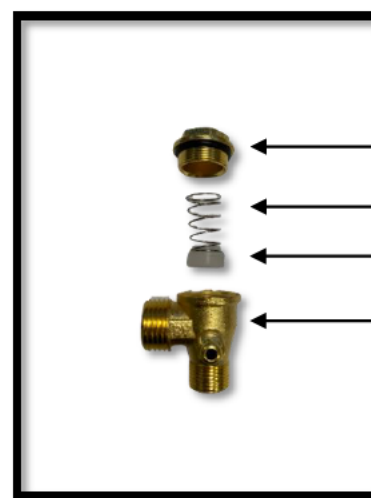

Cap

Spring

Rubber Boot

Non return valve

TROUBLESHOOTING

PROBLEM	POSSIBLE CAUSE	SOLUTION
Compressor does not run	No Electrical power	Check unit is plug in and power point turned on Check fuse/circuit breaker
	Motor overload protection has tripped	Let motor cool and overload protection switch will reset
	Faulty pressure switch	Replace pressure switch
	Tank is full of air	Compressor will only turn on when tank pressure drops to below cut in pressure
	Faulty capacitor in motor	Return to Reseller for inspection and repair
	Faulty motor	Return to Reseller for inspection and repair
Air Leaks	Tube or hose fitting loose	Tighten tube with audible leak and check under pressure with soapy water solution (do not over tighten).
	Leak at weld	Receiver (tank) must be replaced
	Air leak in safety valve (after air compressor is reset)	Return to reseller for inspection and replacement of valve
Restricted air inlet	Dirty air filter	Clean or replace air filter
Low discharge pressure	Prolonged, excessive use of air	Decrease amount of air usage. Compressor is not large enough for air requirements
	Restriction in air filter	Clean or replace air filter
	Tank drain tap open	Close drain tap
	Hole in Hose	Check and replace if needed
Knocking or rattling	Low oil level	Check oil level and adjust to correct level
	Loose screws or nuts	Check all screws and nuts – tighten as necessary

WARRANTY STATEMENT

LIMITED WARRANTY

KEEP YOUR RECEIPT.

Proof of purchase will be required to substantiate any warranty claim.

WHAT IS COVERED:

Powerbuilt warrants to the original retail purchaser in New Zealand that this product is free of manufacturing defect in material and workmanship and agrees, at Powerbuilt's direction, to either repair, provide replacement parts for, or replace (without charge for parts or labor) any product or component with a material defect for a period of 1 year from the date of purchase, except as limited below. Warranty service and replacement parts are warranted only for the duration of the warranty on the original product. All replaced parts or products become a property of Powerbuilt Tools.

Warranty

Powerbuilt's Limited Warranty – 1 Year Residential and 90 Day Commercial.

1 year Residential warranty applies as follow: Parts & Labor for the engine, Frame and pump.

Warranty Term

“Consumer Use” – residential household use by a retail consumer

“Commercial Use” – all other use – commercial, business, industrial, or rental purpose.

How to Obtain Warranty Service

Please contact the Local Distributor who you purchased the product through Please have necessary information available – Model Number, Serial Number, Proof of Purchase. They will contact Powerbuilt Tools and assist you through the warranty process.



WARNING

Repairs to this compressor must be made by a qualify Powerbuilt service agent. Powerbuilt will not be responsible for any damage or injuries cause by the repair or attempted repair by an unauthorized person or by abusing this compressor.

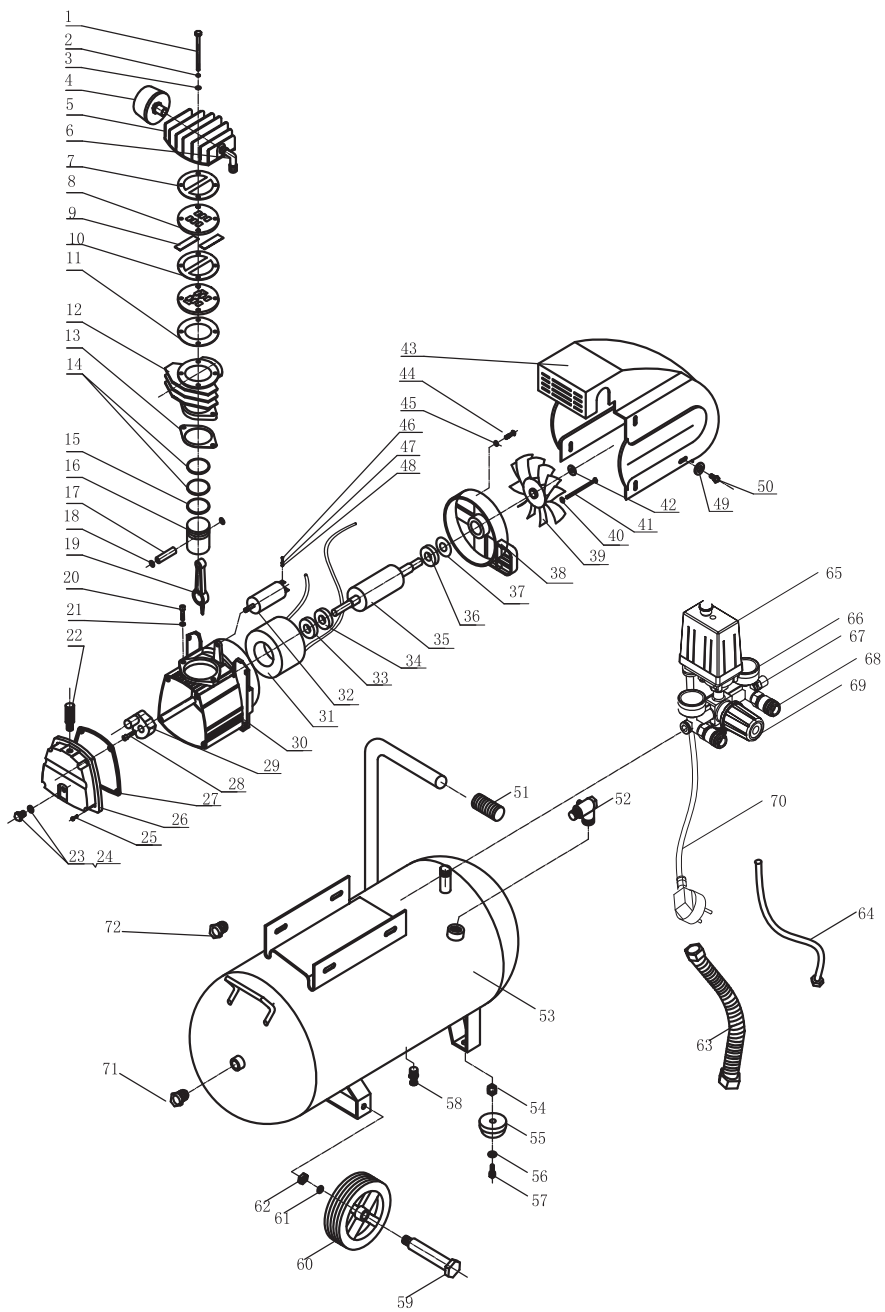

No	Description	Qty		No	Description	Qty
1	BoltM6x55	4		37	washer 202	1
2	spring washer	4		38	motor cover	1
3	washer	4		39	fan	1
4	Air filter	1		40	spring waher 5	4
5	cylinder cover	1		41	bolt M5*105	4
6	elbow	1		42	spring waher 14	1
7	cylinder gasket	1		43	motor cover	1
8	valve plate	2		44	bolt M4*6	1
9	valve clack pin	2		45	washer 4	1
10	valve plate gasket	1		46	bolt M3*6	2
11	cylinder upper gasket	1		47	spring washer 3	2
12	cylinder	1		48	washer 3	2
13	cylinder under gasket	1		49	washer 5	6
14	piston ring	2		50	bolt M5*16	6
15	oil ring	1		51	handle cover	1
16	piston ϕ 47	1		52	one way valve	1
17	piston pin	1		53	tank	1
18	spring washer 12	2		54	bolt M8	2
19	conncting rod	1		55	foot cushion	2
20	bolt M8x25	2		56	washer 8	2
21	spring washer 8	2		57	bolt M8*25	2
22	breather	1		58	drain valve	1
23	oil leveler	1		59	wheel bolt	2
24	wahser	1		60	wheel	2
25	bolt M6*16	4		61	spring washer 10	2
26	crankcase cover	1		62	bolt M10	2
27	crankcase gasket	1		63	discharge pipe	1
28	bolt M8*22	1		64	release pipe	1
29	crank shaft	1		65	pressure switch	1
30	crank case	1		66	pressure gauge Y40	1
31	stator	1		67	safety valve	1
32	capacitance	1		68	coupler	1
33	seal	1		69	regulator valve	1
34	brearing 6204	1		70	power cord with plug	1
35	rotor	1		71	stem Rp1/2	2
36	brearing 6202	1		72	Handle cap	1

NOTES



Powerbuilt is a registered trademark of Alltrade Tools, LLC.

New Zealand Customer enquiries should be directed to: Alltrade Tools NZ (2016) Ltd

support@powerbuilttools.co.nz

www.powerbuilttools.co.nz

Made in China 2021, Alltrade Tools, LLC