

# WELDSAFE™

AUTO DARKENING WELDING HELMET

## User Manual

TO SUIT: **TUNGSTEN** SERIES #WSU2533



VERSION: 2025:1

THIS MANUAL CONTAINS IMPORTANT INFORMATION REGARDING SAFETY, OPERATION, MAINTENANCE AND STORAGE OF THIS PRODUCT. BEFORE USE, READ CAREFULLY AND UNDERSTAND ALL CAUTIONS, WARNINGS, INSTRUCTIONS AND PRODUCT LABELS. FAILURE TO DO SO COULD RESULT IN SERIOUS PERSONAL INJURY AND/OR PROPERTY DAMAGE.



## **SAFETY**



**Please read and understand all instructions before use.**

This Weldsafe Auto Darkening Welding helmet is designed to protect the welders' eyes from harmful radiation, including visible light, ultraviolet radiation (UV) and infrared radiation (IR) resulting from certain arc and gas welding processes under normal welding conditions.

This Weldsafe Welding helmet is suitable for most types of electro-welding, covered electrodes, MIG, TIG, MMA/ARC & Plasma welding & cutting. This helmet is not suitable for laser welding or laser cutting applications.

- The welding helmet is designed to protect the face and eyes from sparks and splatter, the helmet will not protect against explosive devices or corrosive liquids.
- Inspect all operating parts before use to ensure the helmet is free from defects and the Auto Darkening Filter (ADF) is in the welding mode required for your application.
- Ensure that both protective filter covers are free from scratches, dust and clean, as this can affect the performance of the ADF.
- Do not immerse the filter in water, and do not use solvents on the ADF or helmet components.
- If the ADF does not darken when the arc is struck, stop welding immediately and check that the helmet is set to WELD and not GRIND. If the issue continues, please check the manual for the correct setting and follow the steps in the troubleshooting section.
- Never place the helmet or filter on a hot surface.
- Never weld without the protective filter covers.
- Use only within the temperature range of -10°C to +60°C.
- **CONTAINS BUTTON BATTERY. Keep out of reach of children. If a button battery is swallowed or inserted, it can get stuck and start causing significant irreversible damage in as little as 2 hours. Seek medical attention immediately.**

## **FEATURES**

- **Digital Controls** - Four Mode Filter – **Weld, Cut, Grind** and **Dark lock**.  
Clutter-free digital display with memory settings for easy setup. Self-testing facility to ensure your helmet performs as Weldsafe expects
- **Ultimate 1/1/1/1 Optical Clarity Classification**  
Advanced Digital Auto Darkening Filter (ADF) has the highest score across all four classifications, ensuring the most accurate, clearer, brighter view for every weld. Half-shade increments for the ultimate in performance
- **4 Independent Arc Sensors + 1 Ambient** Sense the change in light even at low amperage (5 Amps) switching the ADF to dark mode in 0.05ms, even when welding out of position or part of the filter is blocked.  
The ambient light sensor (Auto sensitivity mode) detects the brightness of the surrounding environment and adjusts the helmet's sensitivity to the welding arc. It helps prevent the lens from darkening in response to ambient light instead of the welding arc itself. This ensures the lens only darkens when a welding arc is present, not when exposed to bright sunlight or other strong light sources.
- **Large Viewing Area:** Our expansive lens gives you a wider field of vision for superior control and visibility.
- **Auto Shade, Auto Sensitivity and Auto Delay** Automatically sets both the optimal shade and sensitivity by sensing your welding environment, with fine-tuned adjustment of +/- 2 shades. Ideal for welders who frequently adjust their settings for changing welding environments. These can be turned on and off independently.
- **TRS (True Rated Shade) Function:** Maintains consistent shade levels for reliable protection.
- **TACK Function** This optimization enhances the user experience by providing a more comfortable and natural transition, reducing eye fatigue caused by intense light, and facilitating a quicker and more intelligent response for the next arc. Ultimately, this leads to a smoother, more efficient arc start while minimising discomfort for the user.
- **Battery Backup** 2 x CR2450 backup batteries to ensure your helmet is ready when you need it.
- **Smooth flip front mask** Easily switch between welding and grinding with a wide 180° grinding view.
- **Integrated side windows** shade 5 on both sides of the helmet enhances surrounding vision for greater safety. Side windows can be blacked out to protect from other nearby welders.
- **5-Point Headgear** Our most comfortable harness provides the perfect fit and stability for all-day wear.

## SPECIFICATIONS

## SPARE PARTS & ACCESSORIES

TUNGSTEN	
Standards	AS/NZS, ANSI, CSA, CE
Viewing Area	116mm x 81mm
Optical Class	1/1/1/1
Arc Sensors	4 & 1 Ambient
True Colour	Ultra True Colour
Operating Display	LCD
ON/OFF function	YES
A/M Function	Shade, Sensitivity, Delay
Self-Check Test	YES
TIG Rating	2A-350A
Shade State	Din 3/4 - 8/9 - 14
Grind Function	Internal Control
Internal Shade Control	Manual
External Shade Control	Internal, ±0.5 increments
Sensitivity Control	Internal
Switching Time	0.04ms
Delay Control (Time Off)	0.05 - 2.0s, Internal
Dark Lock	YES
TRS (True Rated Shade) & TACK Functions	YES
Memory & Recall	Up to 10 records
UV/IR Protection	Permanent
Switching Time	0.04ms
Auto-Shade Deviation	-2.0~+2.0
Power Supply	Solar Cell & Replaceable Li-Battery 2x CR2450
Low Battery	Yes, + Battery Level LED
Warranty	3 years

Replacement Filter Covers	WSUFRG-2533
Neck Protector	WSNP
Head Protector	WSHP-FLIP
Magnifying Lens 1.0	WSML1
Magnifying Lens 1.5	WSML1.5
Magnifying Lens 2.0	WSML2
Magnifying Lens 2.5	WSML2.5
Magnifying Lens 3.0	WSML3
Complete Head Gear	ZWSHGU-2533
Sweat Band	ZWSBAND
ADF Cartridge	ZWSADF-U2533

## PARTS BREAKDOWN

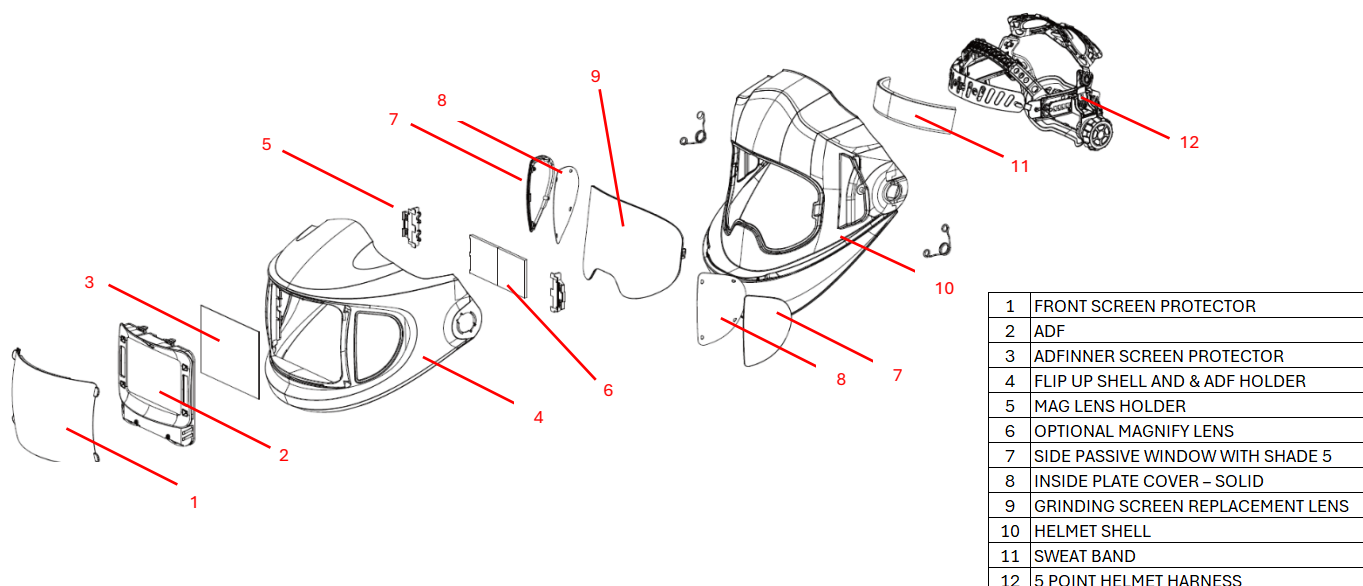

1	FRONT SCREEN PROTECTOR
2	ADF
3	ADFINNER SCREEN PROTECTOR
4	FLIP UP SHELL AND ADF HOLDER
5	MAG LENS HOLDER
6	OPTIONAL MAGNIFY LENS
7	SIDE PASSIVE WINDOW WITH SHADE 5
8	INSIDE PLATE COVER – SOLID
9	GRINDING SCREEN REPLACEMENT LENS
10	HELMET SHELL
11	SWEAT BAND
12	5 POINT HELMET HARNESS

## AUTOMATIC DARKENING HELMET OPERATING INSTRUCTIONS

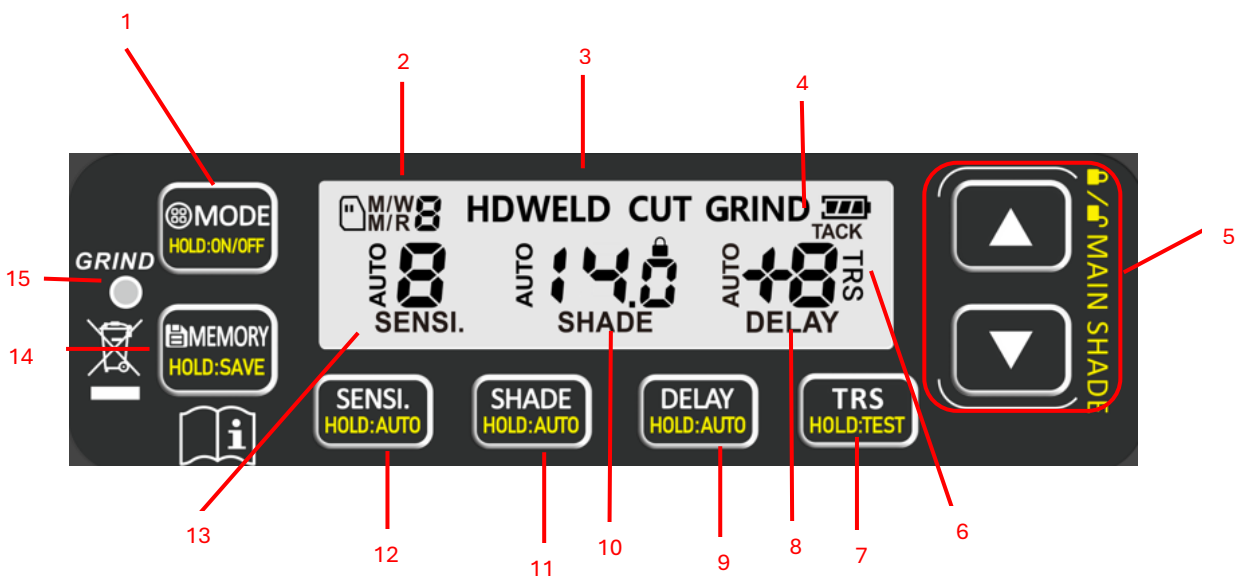

1	MODE / ON OFF	9	DELAY SET / AUTO
2	MEMORY DISPLAY	10	SHADE DISPLAY
3	WELD MODE DISPLAY	11	SHADE SET / AUTO
4	BATTERY LEVEL DISPLAY	12	SENSITIVITY SET / AUTO
5	INCREASE DECREASE / SHADE LOCK	13	SENSITIVITY DISPLAY
6	TRS DISPLAY	14	MEMORY SAVE / RECALL
7	TRS SET / TEST	15	GRIND INDICATOR
8	DELAY DISPLAY		

## ON / OFF

- Your ADF is fitted with an ON / OFF function to save the battery whilst your helmet is in storage. To turn ON or OFF the ADF hold the **MODE** selector until the screen turns ON or OFF.

## ADF SELF-TEST PROCEDURE

- Turn on the ADF System: Ensure that the Auto Darkening Filter (ADF) is powered on. Press and hold the **TRS** button (7). The helmet will begin a series of internal tests to verify that the ADF is functioning properly. Once the self-test is finished, the helmet is ready for use.

## MODE SELECT – WELD, CUT, DARKLOCK & GRIND

- Your ADF features 4 modes to cycle through. Press and release the **MODE** selector button (1) until your desired mode is shown on the digital display.

### WELD MODE

- **WELD** mode is designed for ARC, MIG and TIG welding from Shade 9-14. Please refer to the chart for suggested ranges, and as a rule, it is always better to set your helmet to a darker shade and adjust down depending on the ARC brightness and your sensitivity to light.

### CUT MODE

- **CUT** mode is designed for plasma cutting, gas cutting and brazing from shades 4-8 and should never be used for ARC, MIG or TIG welding.

### DARKLOCK

- **DARKLOCK** mode is designed to work like a traditional welding helmet and the ADF will remain at the selected shade level. In this mode, the ADF will not lighten.
- To set **DARKLOCK**, depress both the **UP and Down** buttons (6) at the same time. Only the shade number will appear.
- To turn off **DARKLOCK**, depress both the **UP and Down** buttons (6) at the same time. All options will now be available.

### GRIND MODE

- The ADF will not darken in **GRIND** mode and shade state 3. To enter **GRIND** mode, cycle the internal MODE selector button (1) until GRIND appears on the Digital display. A secondary red LED light will slowly flash as an added precaution.

**Do not attempt to weld in Grind mode.**



## AUTO SHADE SELECT

- The system automatically adjusts the shade based on the brightness of the welding arc. To activate this, press and hold the **SHADE** select button (11) until the AUTO+ symbol appears on the shade display. You can then fine-tune the automatic setting by the INCREASE/ DECREASE button (6), allowing adjustments of +/- 2 shade levels.

## MANUAL SHADE CONTROL

- To switch from AUTO to MANUAL shade, press and hold the SHADE selection button. When the AUTO+ symbol disappears and only the number remains, you will be in manual mode. If you're not switching from auto, just press the button without holding it. In manual mode, the welding shade will flash, and you can adjust it using the INCREASE/DECREASE buttons.

To set the shade for different modes:

- For shades 4.0 to 8.0, press the **MODE** selector button (1) until "CUT" appears on the digital display. Then you can adjust it using the **INCREASE/DECREASE** buttons (6) to the desired setting.
- For shades 9.0 to 13.0, press the **MODE** (1) selector button until "WELD" appears on the digital display. Then, you can adjust it using the **INCREASE/DECREASE** buttons (6) to the desired setting.



If the ADF does not darken when the arc is struck, immediately stop welding. First, check that the helmet is set to "WELD" or "CUT" mode, not "GRIND." If the issue persists, refer to the manual for the correct settings and follow the troubleshooting steps.

## SENSITIVITY

### AUTO SENSITIVITY

- The system automatically adjusts the sensitivity based on the surrounding lighting conditions. To enable this feature, press and hold the **SENSI** select button (12) until the AUTO symbol appears on the sensitivity display (13).

### MANUAL SENSITIVITY

- To switch to manual sensitivity mode, press the SENSI selection button (12) to cycle from AUTO to MANUAL. If you're not cycling from AUTO, just press the button without holding it. When the AUTO symbol disappears and only the number remains, you'll be in manual control mode. The ADF sensitivity will flash, allowing you to adjust it using the **INCREASE/DECREASE** buttons (6).

#### High Sensitivity:

- Recommended for most applications.
- Ideal for TIG welding with a stable arc.
- Best for low amperage and poor light conditions.

#### Low Sensitivity:

- Use for high amperage welding.
- Recommended when bright ambient light causes the ADF to trigger prematurely (e.g., direct sunlight, intense artificial light, neighbouring welder arcs).

For optimal performance, start with High sensitivity and gradually reduce it until the filter responds only to the welding arc, avoiding unwanted triggering from ambient light.

## DELAY

### AUTO DELAY

- The system automatically sets the optimal **DELAY** by detecting the welding environment. The ADF will adjust the **DELAY** based on the brightness and intensity of the surroundings. To enable this, press and hold the **DELAY** select button (9) until the AUTO+ symbol appears in the delay display (8).

### MANUAL DELAY

- To switch to manual delay mode, press and hold the DELAY selection button (9) to cycle from **AUTO** to **MANUAL**. If you're not cycling from auto, simply press the button without holding it. When "AUTO+" disappears and only the number remains, you'll be in manual control mode. The ADF delay will flash, allowing you to adjust the sensitivity by the internal **INCREASE/DECREASE** buttons (5).

**High Delay** (1.0 second) - Longer delay is for most welding applications, especially for high amperage applications.

**Low Delay** (0.1 seconds) - A shorter delay is for Spot welding applications.

## TRS (TRUE RATED SHADE) FUNCTION

- The ADF will turn from dark to light gradually after welding, instead of immediately giving you more protection. To turn on, press the **TRS** button (7) until the TRS is shown on the display panel. To turn off HOLD the **TRS** button (7) until the TRS is shown on the display panel.

## TACK FUNCTION.

- When 0 delay setting is selected, the ADF uses an intermediate light state 5 to help minimise eye strain during extended tack welding applications. If the ADF does not sense the arc within 2 seconds, the ADF will return to its normal light shade 3.

## MEMORY SAVE AND RECALL

The system allows for up to 9 saved programs to cover all your welding needs.

### SAVING SETTINGS

- Once you have customised all the settings, press and hold the **MEMORY** button (14) for one second; the **MEMORY RECALL** display number will flash (2). Select the desired number by pressing the INCREASE or DECREASE buttons when you have the desired number flashing. wait five seconds without adjusting the ADF, and the program will save.

### RECALL MEMORY

- To recall the saved setting, press the **MEMORY** button (14) and release quickly. The **MEMORY RECALL** display number will flash (2). Select 0-9, the save program will load.

## BATTERY INDICATOR

The battery symbol on your helmet shows the battery backup level. When the symbol starts flashing, it's time to change the battery, as the Auto Darkening Filter (ADF) will no longer function properly.

## CHANGING THE BATTERIES

The welding helmet is powered by solar cells and 2 x CR2450 lithium batteries.

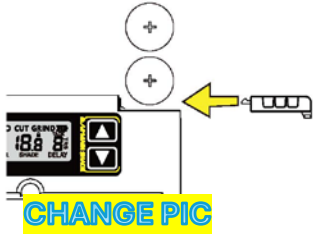

- Remove the ADF Cartridge Frame from the helmet. (See “Removing ADF” on the next page.)
- Remove the ADF from the ADF Holder.
- Slide out the battery cover. Carefully remove the old batteries and insert new ones. Replace the battery cover. Reinsert the ADF into the ADF Holder.
- Reinstall the ADF Cartridge Frame into the helmet.

## REMOVING THE ADF FROM THE HELMET AND CLEANING

- Remove the front screen protector.
  - Lift the flip front shell to allow access to the ADF CARTRIDGE.
  - At the top of the filter, push both tabs down (hard) to release the ADF cartridge and remove out the front.
  - It is necessary to keep the solar cells and light sensors free of dust and splatter.
  - Clean the filter with a soft tissue or cloth in mild detergent (or alcohol).
- NEVER USE AGGRESSIVE SOLVENTS SUCH AS ACETONE

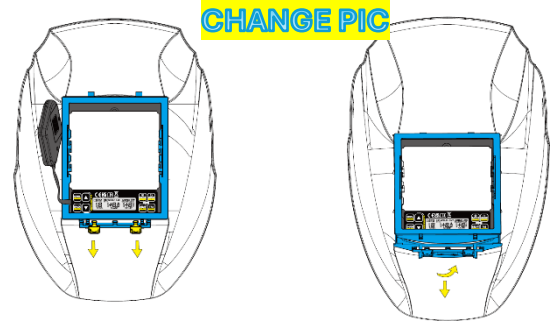

## REPLACING THE FRONT SCREEN PROTECTOR AND GRINDING SCREEN PROTECTOR

### FRONT SCREEN PROTECTOR

- Lift one sides tabs of the front cover and pull that side forward with until it releases from its mounting.
- Once the first side is free, the other side will come out.
- To reinstall, carefully insert one side into the housing and then the other.
- **Note:** Be careful not to use excessive force to avoid cracking the lens or damaging the housing.



### GRINDING SCREEN

- With the flip-front lifted, push the secure tabs from the inside of the helmet .
- To reinstall, carefully position the screen in place and push until the clips click in and are secured.

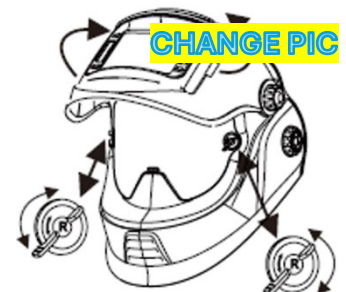

## REPLACING THE INSIDE SCREEN PROTECTOR

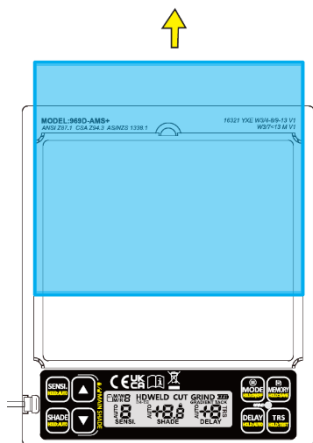

- Pry the inner screen protector up from the finger groove. Slide the old cover up and out.
- Replace with new one (remember to remove both the inner and outer protective film before inserting).

CHANGE PIC

## INSTALLING MAGNIFYING LENS

- Slide the Mags lens retainer clips onto each side of the optional magnification lens.
- Firmly push/clip the retaining clips onto the pins fitted to the ADF housing.
- The lens should now fit firmly in place, if not carefully remove and reinstall.

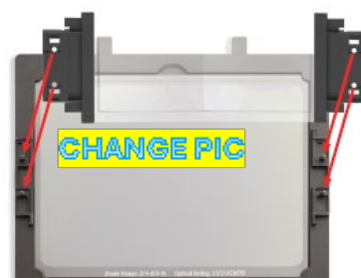

## HEADGEAR OPERATION

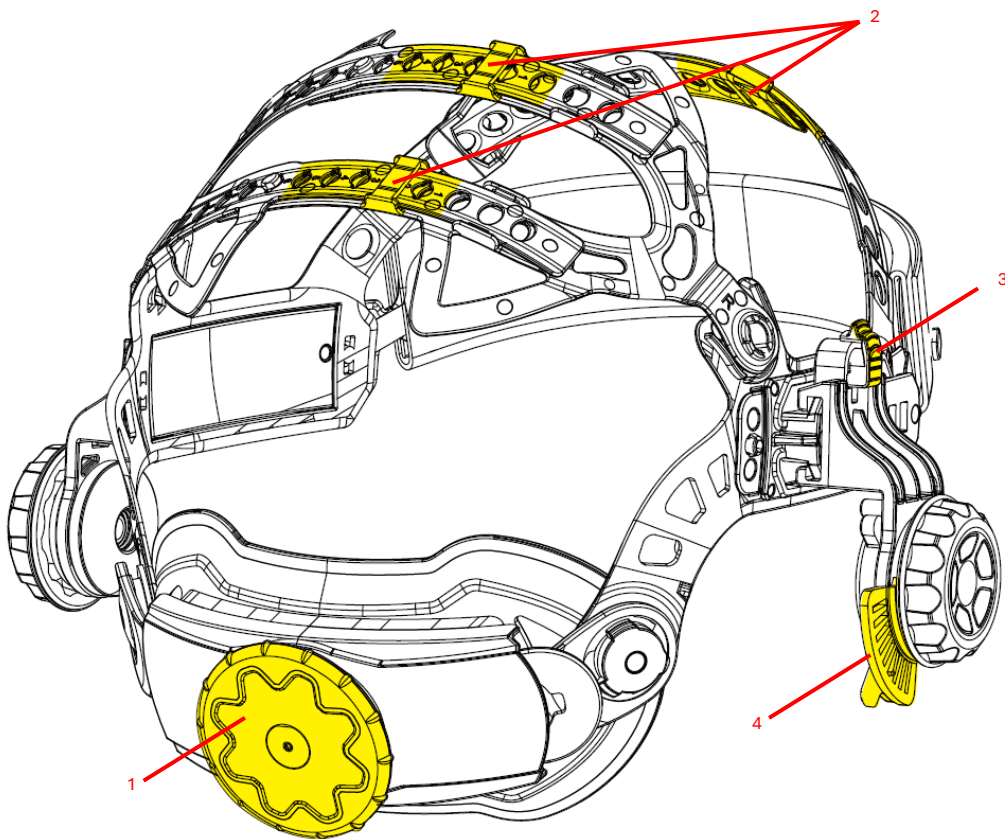

1	NECKBAND ADJUSTMENT DIAL
2	HEAD STRAP ADJUSTMENT
3	DISTANT ADJUSTMENT BUTTON
4	ANGLE ADJUSTMENT

### NECKBAND ADJUSTMENT

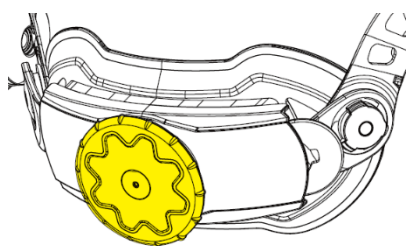

- To tighten the neckband, turn the **NECK BAND ADJUSTMENT DIAL** clockwise to a comfortable adjustment.
- To loosen the neck bank, turn the **NECK BAND ADJUSTMENT DIAL** counterclockwise to a comfortable adjustment.

### HEAD STRAP ADJUSTMENT

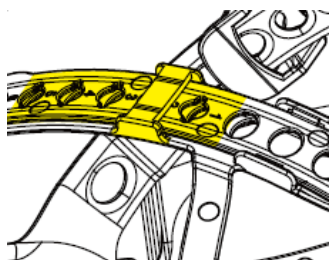

- Adjust the headgear straps by locating the lock-in pin. Push the pin away from the hold. Adjust the strap to a comfortable size lock pin back in place.
- Continue with the other straps to ensure correct balance and stability.

## DISTANCE ADJUSTMENT

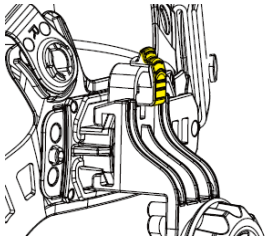

- To adjust the distance between your face and the ADF push the DISTANCE ADJUSTMENT BUTTON in the headgear closer or away from the ADF inside the helmet.

## ANGLE ADJUSTMENT

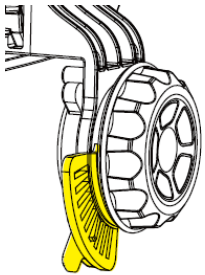

- There are multiple pins on the right side of the headgear allowing for tilt adjustment to the helmet when the helmet is in the down position.
- To adjust loosen the tension adjustment knob, reposition it to the desired notch and retighten the tension adjustment knob.

## TROUBLESHOOTING

FAULT	POSSIBLE CAUSE	SOLUTION
Irregular Darkening Dimming	Headgear has been set unevenly, creating an uneven distance from your eyes to the filter.	Reset the headgear to reduce the difference in the filter.
The filter triggers when not welding or stays dark.	Bright ambient light or other welding close by	Lower sensitivity until the helmet no longer false triggers.
	Set to <b>DARKLOCK</b>	Check mode is set to <b>WELD</b> or <b>CUT</b> .
The Filter does not darken when welding	<b>GRIND</b> mode on	Check mode is set to <b>WELD</b> or <b>CUT</b>
	Battery Flat	Replace batteries
	Front cover lens dirty or damaged	clean or replace the front protective cover.
	Sensors are dirty / blocked or the solar panel is blocked	Clean sensor surfaces to make sure they are free from dust and smoke residue.
	Sensitivity is set too low or delay time is set too short	Adjust to the required level - a higher delay should stop flickering.

### Note:

If after checking above your helmet does not darken or is not functioning correctly, immediately stop welding and contact your place of purchase or WELDSAFE directly. Do not attempt to modify the welding helmet or Auto Darkening Filter (ADF) in any way. Only use spare parts and accessories as stated in this manual. Use of unauthorized parts or modifications will void the warranty.

## **WELDING HELMET WARRANTY**

Your Weldsafe welding helmet is covered by a 36-month warranty, which protects against faulty materials and manufacturing defects. If your helmet fails during this period, please contact your authorised Weldsafe distributor for assistance.

### **Warranty Coverage:**

The warranty covers defects in materials or workmanship.

If a failure is identified, Weldsafe will inspect the helmet and, if repair is not feasible, the helmet will be replaced.

### **Exclusions:**

Freight costs are not covered under the warranty.

The warranty does not apply to products that have been serviced by unauthorised personnel.

For warranty claims, please ensure you contact an authorised Weldsafe distributor.

## **SHADE SELECTION CHART**

Process	Current A																															
	1.5	6	10	15	30	40	60	70	100	125	150	175	200	225	250	300	350	400	450	500	600											
Covered electrodes	8				9				10				11				12				13				14							
MAG	8				9				10				11				12				13				14							
TIG	8				9				10				11				12				13											
MIG with heavy metals					9				10				11				12				13				14							
MIG with light alloys									10				11				12				13				14							
Air-arc gouging									10				11				12				13				14				15			
Plasma jet cutting									9				10				11				12				13							
Microplasma arc welding	4		5		6		7		8		9		10		11		12															
	1.5	6	10	15	30	40	60	70	100	125	150	175	200	225	250	300	350	400	450	500	600											

NOTE The term "heavy metals" applies to steels, alloy steels, copper and its alloys, etc.